

# Corus Evo Compact

Electronic Volume Gas Converter for Commercial and Industrial use



Corus Evo Compact is an electronic volume converter for commercial and industrial natural gas applications. By measuring temperature and pressure from the gas flow in the meter, Corus Evo Compact provides extremely accurate data improving billing precision for utilities and gas distributors. With superior accuracy certifications, simplified maintenance, Corus Evo Compact is the fundamental component of a reliable gas distribution solution for C&I customers.



## Safeguards Billing Processes

Conceived to safeguard billing processes, Corus Evo+ offers the unique capability to measure gas consumption with a certified 0.5% accuracy\*. With embedded anti-tampering, security and encryption features, Corus Evo Compact ensures precision and security in the billing process for utilities.



## Simplifies Field And Maintenance Operations

Built with proven components, Corus Evo Compact features external pressure sensors that facilitate field operations. Enclosed calibration coefficients alleviate on-site maintenance and simplify the replacement of units in the field. With an intuitive Human-Machine Interface crafted through decades of expertise, Dresser Actaris Gas's Corus Evo Compact helps streamline field and maintenance efforts.



## Evolves With Your Needs

Supporting alarms with on-site reading, Corus Evo Compact is programmable to trigger alerts based on user-defined events. Upgradeable remotely, Corus Evo Compact adjusts to current and future needs from the field.

## Features

- » High accuracy: compliant with MID according EN12405-1:2018 (0.5%) with optional Class A accuracy (0.3%) according EN12405-2:2012
- » ATEX and IEC Ex approved for hazardous area zone 0 or 1
- » Up to 12 years autonomy
- » IP 66 Enclosure
- » Tampering detection features
- » Encrypted communication with individual keys
- » Energy index management
- » Operating temperature range: -25°C to +70°C
- » Graphic LCD
- » Integrated cellular modem

\*Optional.

# Standard Product Features

## Metrology

T, PT or PTZ type 1 converter

- » 0.5% accuracy conform to EN12405-1:2018 (MID approval)
- » Optional class A available (0.3%) conform to EN12405-2
  
- » MID approval by CMI (module B)
- » MID production approval by PTB (module D)
  
- » Gas temperature range:
  - - 25°C to +70°C
  - -40°C to +70°C optional
  
- » Ambient Temperature Range:
  - Standard -25°C to +70°C
  
- » Available Z calculation formulae:
  - S-GERG 88
  - AGANX19 mod
  - GOST 30319,2-2015
  - GOST 30319.3-2015
  - AGA8 – Gross method (GM1 or GM2)
  - AGA8 – Detailed method (DM)
  
- » Energy calculation and display conform to EN12405-2

## Anti-tampering features

- » Box opening detection
- » Meter magnetic tampering detection (via anti tampering input and reed detector of meter).
- » Back-flow management
- » Support operation with passwords and encrypted communication with unique keys per device for the encryption.

## Communication

- » Standard 1 optical port (EN 62056-21), 1 RS232/485 port  
*options available p.3*
  
- » Main supported protocols:
  - IFLAG Evo
  - Modbus RTU
  - Modbus Enron
  - Modbus TCP
  - Idom
  - CTR

## Sensors

- » MID approved pressure ranges (bar):  
0.6 – 5.2 ; 0.8 - 5.2 ; 2 - 10 ; 4 - 20 ; 7- 35 ; 14 - 70
- » MID approved extended pressure ranges (bar):  
0.60 - 10 ; 0.8 - 10 ; 0.8 - 20 ; 4 - 70
  
- » Non MID approved ranges (gauge) (bar):  
0 - 0.2 ; 0 – 1 ; 0 - 1.6 ; 0 – 4 ; 0 – 6 ; 0 – 10 ; 0 – 25 ; 0 – 40
  
- » Non MID pressure ranges:
  - accuracy 0.4% full scale - below 1 bar
  - accuracy 0.2% full scale - above 1 bar
  
- » Pressure sensor type: External piezo-resistive transducer with integrated coefficients for linearisation
  
- » Temperature transducer: Transducer with platinum probe sensor- PT1000 with integrated coefficients for linearisation
- » Metering input (volume): Low frequency type (2Hz max), signal from reed sensors of Cyble Sensor ATEX). A second LF or an HF input can be used for coherence check of metering input.  
*With optional module p.3 : High Frequency (3kHz max), Namur Encoder input (Cyble SC or other Namur encoders).*
  
- » Cables length: Max 2.5m

## Database

- » Permanent memory FRAM for the parameters and a FLASH memory for the database.
- » Flexible configuration for storage of selected items into the different logs.
- » Database structure:
  - Monthly archive (up to 80 years)
  - Daily archive (up to 11 years)
  - Billing archive (up to 10 years)
  - Hourly (up to 12 years)
  - Binary archive
  - Status archive
  - Settings archive
  - Gas composition archive (up to 5 years)

## Power Supply

- » Internal back-up lithium battery (part of the CPU module)
- » Standard battery 17Ah lithium – up to 12 years
- » EVC external power supply

*options available p.3*

## Environmental

- » Ambient temperature range:
  - -25°C – +70°C with graphic display
  - -40°C – +70°C with alphanumeric display (optional)
- » IP 66 protection
- » Polycarbonate enclosure
- » Mechanical Environment Class M2
- » Electromagnetic Environment Class E2
- » Designed for condensing and non-condensing humidity environments.

User Interface	LCD backlit display, 128 x 64 pixels
Language Support	English, other languages available upon request
Keyboard	6 keys – Capacitive type
Units of main data	Pressure (absolute): bar, psi, kPa, kgm/cm <sup>2</sup> Temperature: °C, °F, °R Volume: m <sup>3</sup> , ft <sup>3</sup> Energy: MJ, kWh, Btu
Dimensions	268 x 182 x 61 mm
Weight	2 kg

## Standards

- » 2014/34/EU ATEX
- » 2014/30/EU EMC
- » 2014/32/EU MID
- » 2014/53/EU RED
- » 2011/65/EU RoHS
- » 2012/19/EU WEEE2

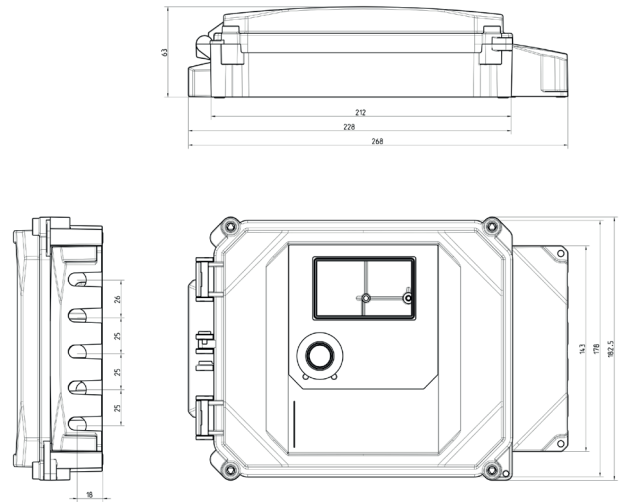

## Modularity And Available Options

### Optional Modules

For remote communication the following modules:

- » Module with 2G / 3G / 4G LTE Cat 1 cellular modem
- » Module with 4G LTE M1 cellular modem
- » Module with 4G LTE NB-IoT cellular modem

### Other Options

- » EVC part batteries selection:
  - Lithium battery (30Ah) - up to 15 years
  - Alkaline battery - 6 years
- » Modem battery options:
  - GSM/GPRS modem, lithium battery, 12Ah - 6 years
  - GSM/GPRS modem, lithium battery, 20Ah - 11 years
  - LTE modem, lithium battery, 12Ah - 6 years
  - External power supply for Modem

## Accessories

- » Configuration software Wincor Evo
- » Optical probe
- » External antenna
- » Isolator pulse
- » Isolator serial com port
- » Analog output external module CLO
- » Mounting kit for pipe installation
- » Thermowells
- » 3 way valve for pressure transducer

## Dresser Utility Solutions GmbH

Hardeckstr. 2  
76185 Karlsruhe  
T: +49 (0)721 / 5981 - 0  
info.karlsruhe@dresserutility.com



© 2025 Dresser Utility Solutions GmbH – All rights reserved. Dresser Utility Solutions reserves the right to make changes in specifications and features shown herein, or discontinue the product described at any time without notice or obligation. Contact your Dresser Utility Solutions representative for the most current information. The Dresser Logo and all Trademarks containing the term "Dresser" are the property of Dresser, LLC, a subsidiary of Baker Hughes. Actaris™ is a trademark owned by Itron, Inc. and used under license.

810-099-4024 AGM Corus Evo Compact Brochure DUS.AGM.EN.0021.AA  
01.25

## Manas Enerji Yönetimi Sanayi ve Ticaret A.Ş.

ASO. 1. Organize Sanayi Bölgesi Anadolu  
Caddesi No:25 SINCAN/ANKARA/TÜRKİYE

Tel: +90 312 267 05 03  
Mail: export@manas.com.tr

**MANAS**  
Innovation For Future  
DRESSER Channel Partner



For more information  
[manas.com.tr](http://manas.com.tr)